



Blade 2.0

EN Acoustic Blade 2.0 is an extraordinary acoustic luminaire. By using a PET panel with a large surface area, we have created a lamp that absorbs and isolates a significant proportion of ambient sounds. Due to its form, it can also serve as a partial barrier in open-plan offices. The lamp is equipped with high-quality light sources, making it a perfect fit for workplaces.

DE Acoustic Blade 2.0 ist eine Akustiklampe der besonderen Art. Dank des großflächigen PET-Moduls absorbiert und isoliert diese Lampe einen großen Teil der Umgebungsgläusche. Aufgrund der Form kann das Modell auch als eine Art Teiltrennwand in Open Space-Bürräumen eingesetzt werden. Die Lampe ist mit hochwertigen Lichtquellen ausgestattet und eignet sich daher ideal für den Arbeitsplatz.

Quickinfo

size	Blade 2.0 M	Blade 2.0 XL
luminaire size	1190×390×53	1750×290×53
light source size	1134×28	1694×28
system power	↓19.6W*	↓29.4W*
luminous flux	↓2234lm*	↓3351lm*
UGR	<19	<19

Technical information

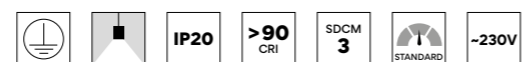

light distribution - down	120° opal	
	60° microprismatic	
	65° dark optics	
	55° dark optics	
luminous efficiency	113lm/W*	
electrical control	ON / OFF	▲ 9
	DALI	▲ 8
color temperature	3000K	● 3
	4000K	● 4
	on request: TUNABLE WHITE	● 9
luminaire color	black 9005	◆ 01
	white 9010	◆ 02
optics	opal	* 10
	microprismatic	* 11
	dark optics 65° (black reflector)	* 20
	dark optics 65° (white reflector)	* 21
	dark optics 65° (silver reflector)	* 22
	dark optics 55° (black reflector)	* 23
	dark optics 55° (white reflector)	* 24
	dark optics 55° (silver reflector)	* 25
fabric color	ARCHI felt color palette archixxx - choose color from page 202	◆ archixxx

* Photometric data: dark optics 65°, white reflector, 4000K

Create my unique code!

2114 - 00 - 2 - ▲ - ● - ◆ - * - 2 - ◆

Example

Blade 2.0 ↑
2114 - 00 - 2 - 8 - 4 - 01 - 20 - 2 - archi1201
↓ one size ↓ DALI ↓ luminaire black 9005 ↓ pendant

standard power ↑ 4000K ↑ dark optic 65° with black reflector ↑ ARCHI felt color 1201 ↑



ING KATOWICE MAŁECY BIURO PROJEKTOWE

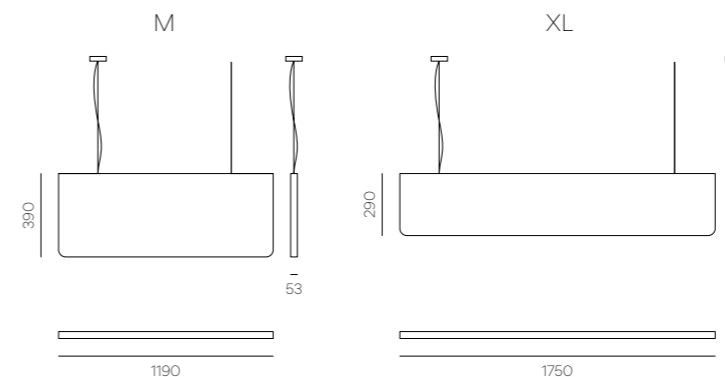

On request we can produce it in other sizes!

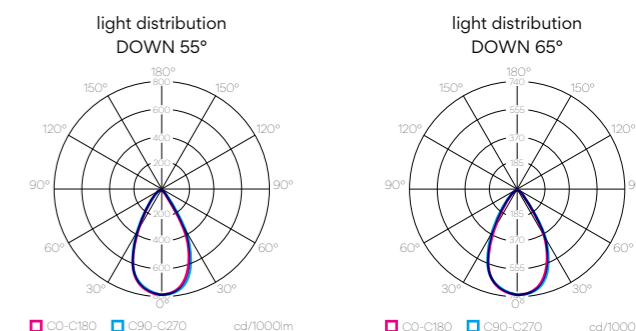

ARCHI felt ecoPET 12 mm

EN The high-quality PET sound panels are robust, durable, and have a slightly textile surface that can be washed. They have excellent sound-absorbing properties, are flame-resistant and recyclable.

DE Hochwertige PET-Akustikplatten sind massiv, strapazierfähig, mit einer leicht textilen Oberfläche, die gewaschen werden kann. Sie haben hervorragende Schalldämmeigenschaften, sind schwer entflammbar und können recycelt werden.

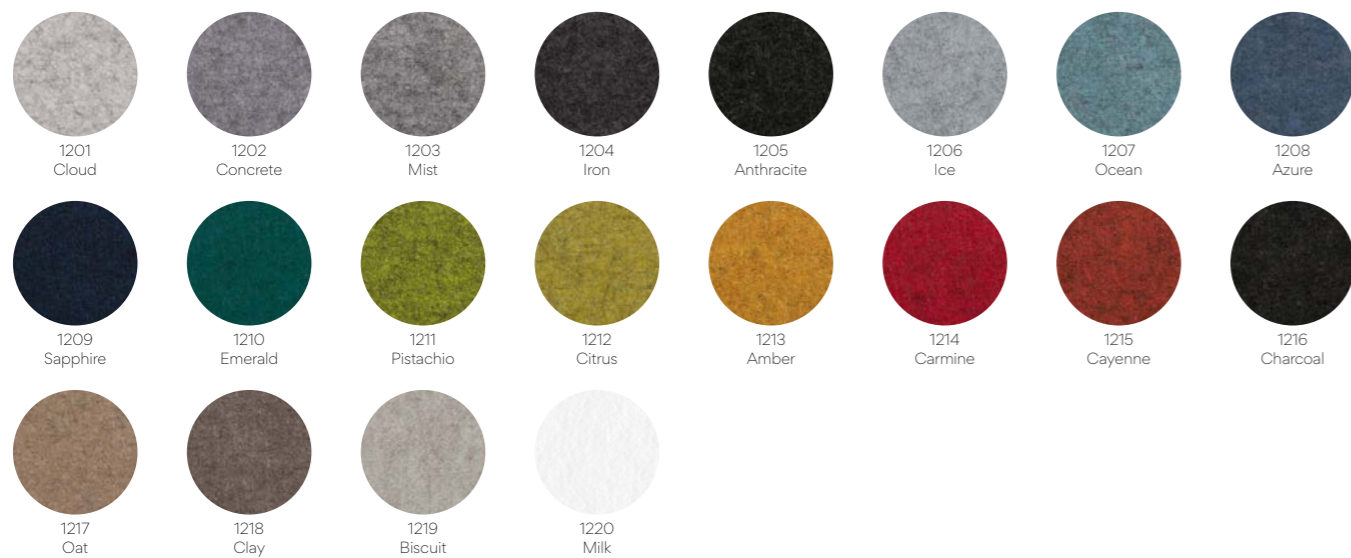

ARCHI felt ecoPET properties

Measurements

2800 mm × 1200 mm × 12 mm

gross size

Flammability Class

B-s1,d0

Acoustic values

Mounting method	Directly on the wall	50 mm cavity	50 mm cavity + 50 mm rockwool	100 mm cavity	100 mm cavity + 100 mm rockwool
NRC (100–5000 Hz)	0.40	0.75	0.95	0.80	1.00
aw (100–5000 Hz)	0.25	0.60	1.00	0.80	0.95
Acoustic Class	D	C	A	B	A