



Sol

EN Sol, which stands for “sun” in Swedish, provides performance and atmospheric lighting and improves acoustics. It emits high-quality diffused light in both ways. Downward light is additionally spread by a micro prismatic diffuser, creating perfect working conditions. Upper light brightens up the room by filling it with a pleasant glow. Sol is made from ecoPET – synthetic felt panels manufactured from recycled PET bottles that solve the acoustic problems in interior spaces. ecoPET is non-flammable, very durable, and easy to maintain, and at the same time, it is delicate and soft to touch. It is created from recycled material and is possible to be recycled again. The material’s strength allows for clever construction from flat-cut pieces of panels.

DE Sol, das auf Schwedisch für „Sonne“ steht, sorgt für Performance und atmosphärisches Licht und verbessert die Akustik. Sie gibt in beide Richtungen hochwertiges diffuses Licht ab. Nach unten gerichtetes Licht wird zusätzlich durch einen mikroprismatischen Diffusor gestreut und schafft so perfekte Arbeitsbedingungen. Oberes Licht erhellt den Raum, indem es ihn mit einem angenehmen Schein füllt. Sol besteht aus ecoPET – synthetischen Filzpaneelen, die aus recycelten PET-Flaschen hergestellt werden und die akustischen Probleme in Innenräumen lösen. ecoPET ist nicht brennbar, sehr langlebig und pflegeleicht und gleichzeitig zart und weich im Griff. Es wird aus recyceltem Material hergestellt und kann wieder recycelt werden. Die Stärke des Materials ermöglicht eine clevere Konstruktion aus flach geschnittenen Stücken.

Quickinfo

size	Sol S ■ 01	Sol M Sol L ■ 02 ■ 03	Sol XL ■ 04
luminaire size	Ø 1000×120	M Ø 1150×120 L Ø 1500×120	Ø 1950×120
light source size	Ø 450×82	Ø 600×82	Ø 900×82
system power	30W (+9W +21W)	48W (+14W +34W)	80W (+24W +56W)
luminous flux	↑1000lm ↓2100lm	↑1750lm ↓3500lm	↑3400lm ↓5600lm
UGR	<18	<17	<15

Technical information

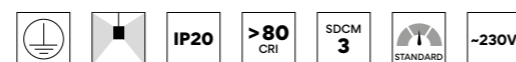

light distribution - up	100°
light distribution - down	95°
luminous efficiency	110lm/W
electrical control	ON/OFF ▲9 DALI ▲8
color temperature	3000K ●3 4000K ●4 on request: TUNABLE WHITE ●9
luminaire color	black 7021 ◆01 white 9003 ◆02
fabric color	ARCHI felt color palette archixxx – choose color from page 202 ◆archixxx

Create my unique code!

2120 - ■ - 2 - ▲ - ● - ◆ - 00 - 3 - ◆

Example

Sol
↑
2120 - 01 - 2 - 8 - 4 - 01 - 00 - 3 - archi1201
↓
size S DALI luminaire black 7021 pendant up & down

standard power 4000K no frame ARCHI felt color 1201

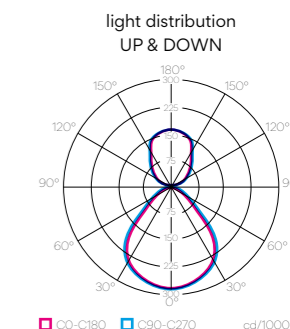
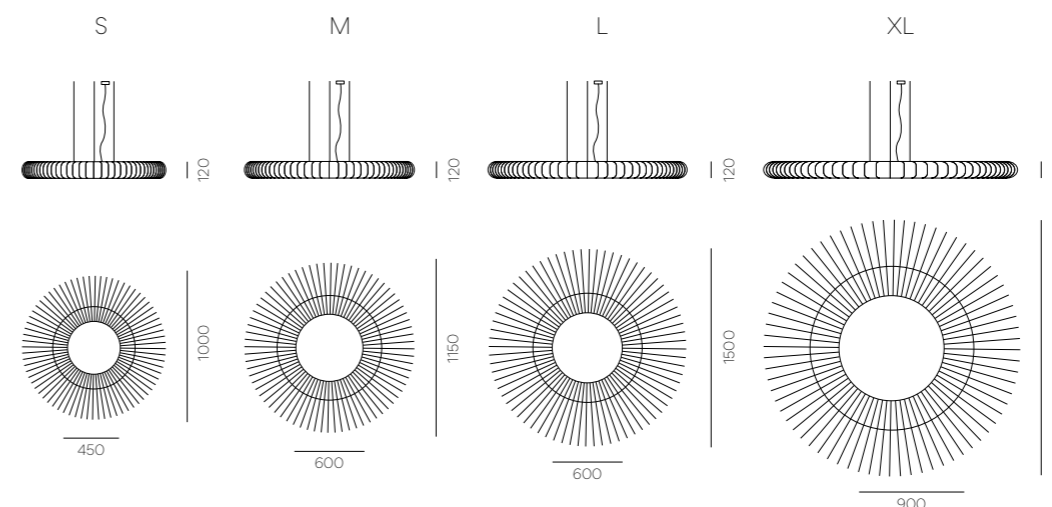

ARCHI felt ecoPET 12 mm

EN The high-quality PET sound panels are robust, durable, and have a slightly textile surface that can be washed. They have excellent sound-absorbing properties, are flame-resistant and recyclable.

DE Hochwertige PET-Akustikplatten sind massiv, strapazierfähig, mit einer leicht textilen Oberfläche, die gewaschen werden kann. Sie haben hervorragende Schalldämmeigenschaften, sind schwer entflammbar und können recycelt werden.

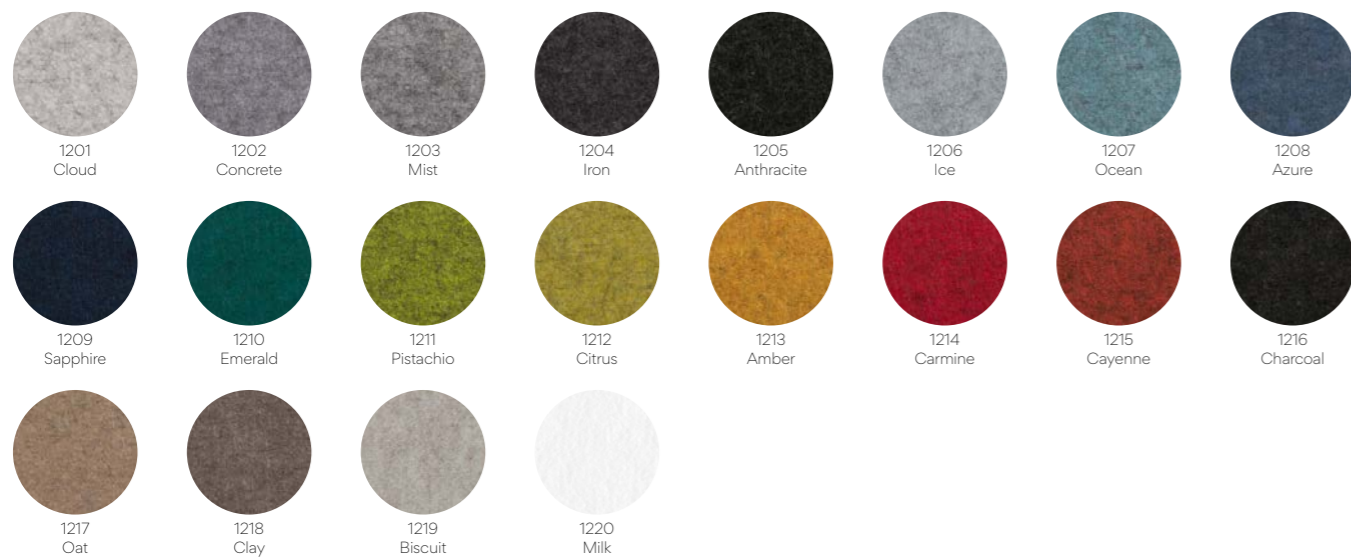

ARCHI felt ecoPET properties

Measurements

2800 mm × 1200 mm × 12 mm

gross size

Flammability Class

B-s1,d0

Acoustic values

Mounting method	Directly on the wall	50 mm cavity	50 mm cavity + 50 mm rockwool	100 mm cavity	100 mm cavity + 100 mm rockwool
NRC (100–5000 Hz)	0.40	0.75	0.95	0.80	1.00
aw (100–5000 Hz)	0.25	0.60	1.00	0.80	0.95
Acoustic Class	D	C	A	B	A